

# **D-Link<sup>®</sup>**

## **Ethernet**

### **Unmanaged Hub**

**D-Link<sup>®</sup>**  
**Lifetime**  
**Warranty**

**10BASE-T STANDARD**  
**WORKGROUP HUB**



**Simple plug and play installation**

**FREE lifetime customer support**

**Easy to use with built-in error  
detection and correction**

**Flexible design that's rack-  
mountable & suitable for desktop  
use**

***User's Guide***

---

# Table of Contents

---

About this Guide .....	1
Rack Mounting .....	2
Installing Network Cables.....	3
Station Connections with	
Twisted-Pair Cable.....	4
Hub-to-Hub connections with	
Twisted-Pair Cable.....	4
Thin Coaxial Cable Connections.. .....	.7
Thick Coaxial Cable Connections.....	9
Connecting Power.....	9
LED Indicators.....	10
Specifications .....	11

Rev. 06 (April '98)  
6DE824TP..06  
Printed In China

---

## About this Guide

---

This guide provides instructions for installing all of the products described below. These D-Link® Ethernet Hubs are all Plug and Play compliant for easy installation.

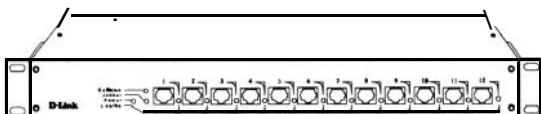

**DE81 2TP+**

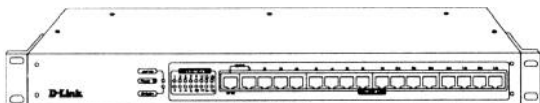

**DE-81 6TP**

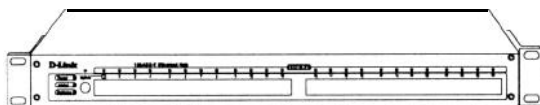

**DE-824TP**

When designing your cable configuration, it is necessary to strictly observe the Ethernet cabling rules. This manual assumes familiarity with the fundamental Ethernet cabling rules and limits; it only describes the details of cable connection.

---

# Rack Mounting

---

The Ethernet Hub may stand alone, or may be mounted in a standard 19-inch equipment rack. Rack mounting produces an orderly installation when you have a number of related network devices. Use the six supplied screws to fasten the supplied mounting brackets to either end of the hub, then fasten the hub into the rack.

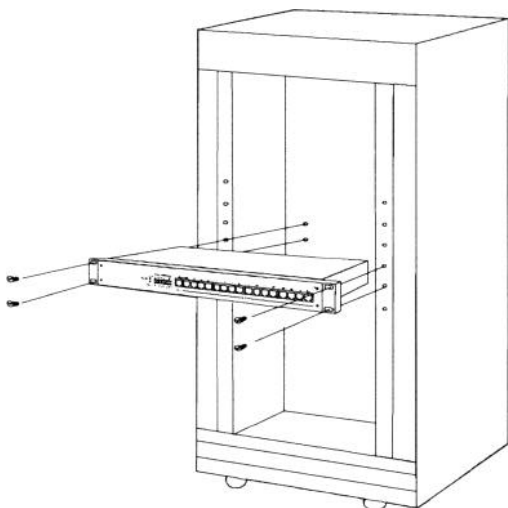



---

# Installing Network Cables

---

Your Ethernet Hub is denominated as an 12-port, or 16-port, or 24-port Ethernet Hub according to the number of its front-panel 10BaseT ports. Additionally it has two ports whose connectors are on the rear panel: one 10Base2 port (BNC connector), and one 10Base5 port (AUI connector). These two un-numbered rear-panel ports are logically equivalent with the numbered ports on the front panel of the Ethernet Hub.

By using a rear-panel connector of the Ethernet Hub to connect into an existing coaxial network cable, you can add on a star-topology subnet, connected through the Ethernet Hub's numbered front-panel ports. Alternatively, you can connect into an existing star-topology through a front panel port of the Ethernet Hub, and then add on a bus-topology subnet by connecting the subnet bus to a rear-panel connector of the Ethernet Hub (irrespective of any star-topology subnet that may also be supported by the Ethernet Hub's front-panel ports). In either case, the unused rear-panel connector always remains available to connect a second coaxial cable (alternative type of coaxial cable).

When the Ethernet Hub has no coaxial trunk connection, then both of the rear panel connectors remain available for coaxial station-cable connections. It is useful to keep this in mind when you have some station equipment whose adapters have no 10BaseT port (RI-45 connector), and thus can only be connected to the hub through a coaxial cable.

## ***Station Connections with Twisted-Pair Cable***

Connect each station to the Ethernet Hub by means of a twisted-pair straight cable (10BaseT cable, Category 3, 4, or 5). Plug one RJ-45 connector into a front-panel port of the Ethernet Hub, and plug the other RJ-45 connector into the station's Ethernet adapter.

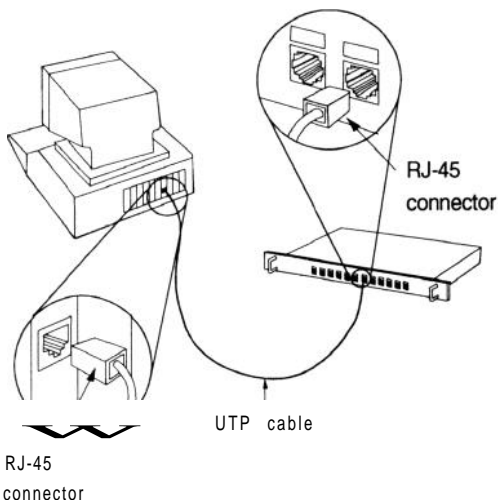

## ***Hub-to-Hub Connections with Twisted-Pair Cable***

Hub-to-hub connection between Model DE-812TP+ Ethernet Hubs requires a 10BaseT crossover cable. In making a hub-to-hub

connection involving a Model DE-816TP or Model DE-824 Ethernet Hub, there is the alternative of using a straight cable.

---

## **Internal Crossover Features**

The Model DE-816TP Ethernet Hub and DE-824TP Ethernet Hub feature internal cross-over alternatives for Port 1:

+ **Model DE-816TP Ethernet Hub**

The port numbered as Port 1 is identical with each of the other numbered ports. But Port 1 is specially equipped with an alternative connector, labeled "Uplink." The Uplink connector is wired to the same conductors as the Port 1 connector, but with certain pin positions interchanged to provide a cross-over, and thus allow use of a straight cable to make a hub-to-hub connection.

Keep in mind that the Uplink connector is not an independent-port. It is only an alternative connector to Port 1, to facilitate hub-to-hub cabling. Port 1 is fully occupied whenever (1) a hub-to-hub connection is made through its Uplink connector, or (2) any kind of connection is made directly through the Port 1 connector

Below in this manual, the term "Uplink selected" will mean, as to the Model DE-816TP Ethernet Hub in question, that the subject connection is made through the Uplink connector

## + Model DE-824TP Ethernet Hub

The connector numbered as Port 1 is equipped with a switch labeled "Uplink". When the Uplink switch is in the "off (tall)" position, the Port 1 connector is wired "straight" to the supporting circuitry, and Port 1 is then identical with each of the twenty-three other numbered ports. When the Uplink switch is in the "on" (depressed) position, a pin interchange is switched into the wiring for the Port 1 connector, to provide a cross-over, and thus allow use of a straight cable to make a hub-to-hub connection.

Below in this manual, the term "Uplink selected" will mean, as to the Model DE-824TP Ethernet Hub in question, that the subject connection is made through Port 1 and the Uplink switch is in its "on" (depressed) position.

---

### **Rules for Using the Uplink Feature**

Uplink should never be selected for a station cable connection. And Uplink should never be selected for a hub-to-hub connection through a crossover cable (because the crossover in the connector wiring would cancel out the crossover in the cable).

Uplink should be selected only for making a hub-to-hub connection with a straight cable. When Uplink is selected at one end of a straight cable, Uplink must not be selected at other end of that cable. (If Uplink were selected at both ends of a straight cable, then the built-in crossovers of the

two connectors would cancel one another, and the hub-to-hub connection would fail.)

Thus the rule for making a hub-to-hub connection with twisted-pair cable is as follows:

To make a hub-to-hub connection with a **straight cable**, Uplink *must* be selected at one end of the cable, and Uplink *must not* be selected at the other end of the cable.

To make a hub-to-hub connection with a **cross-over cable**, Uplink *must not* be selected at either end of the cable.

## ***Thin Coaxial Cable Connections***

To connect the Ethernet Hub to a thin coaxial cable (IOBase2 cable, also known by its wire-standard name, RG58A/U, and a variety of other informal names), first twist a BNC T-connector onto the rear-panel BNC connector of the Ethernet Hub. Then twist the shell of the cable's connector onto either leg of the BNC T.

If the thin coaxial cable continues on to other nodes, then twist the shell of the continuation cable onto the remaining leg of the BNC T. If there is no continuation (the Ethernet Hub is at the end of the coaxial cable), then it is necessary to twist a 50-ohm terminator onto the remaining open leg of the BNC T.

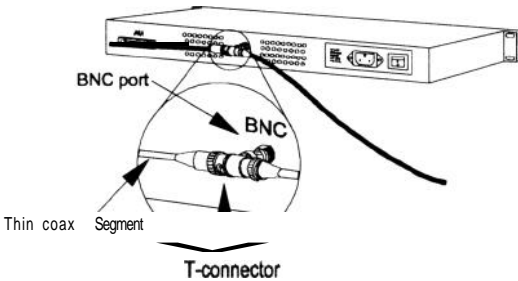

Sometimes several Ethernet Hubs must be co-located to support a larger array of stations than can be handled by a single Ethernet Hub. Then it is useful to stack the Ethernet Hubs by joining their BNC connectors with 0.5 meter patches of thin coaxial cable. Such stacking is just a special case of thin coaxial cable connection as treated above, and the terminator rule is the same: If the stack is at the end of the incoming cable, then a 50-ohm terminator must be substituted for the continuation cable shown in the stacking diagram below.

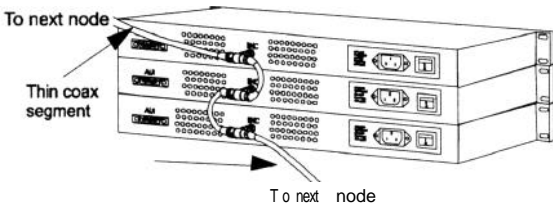

## ***Thick Coaxial Cable Connections***

To connect the Ethernet Hub to a thick coaxial cable (IOBase cable), it is necessary to have a IOBase Ethernet transceiver (tap) on the cable at the Ethernet Hub's position. Then run an AUI cable between the transceiver's AUI connector and the AUI connector on the rear panel of the Ethernet Hub.

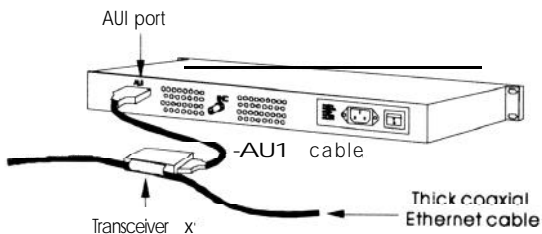

---

## **Connecting Power**

---

For compatibility with electric service in most areas of the world, the Ethernet Hub's power supply automatically adjusts to line power in the range 100 - 240 VAC and 50 - 60 Hz.

Per ordering option, either a Type 1 (US) or Type 2 (European) power cord is supplied with your Ethernet Hub. See Specifications, below, for power cord details.

Ascertain that the power switch on the rear panel of the Ethernet Hub is in the off position. Plug the female end of the power cord firmly into the

---

receptacle on the rear panel of the Ethernet Hub. Plug the other end of the power cord into an electric service outlet. Turn on power to the Ethernet Hub by switching its rear-panel power switch to the *on* position.

---

## LED Indicators

---

LED indicators are located on the front panel of the Ethernet Hub.

### ◆ Jabber LED

One Jabber LED for all ports. This LED flashes red when the Ethernet Hub detects a data packet that is defective (exceeds allowable length). This kind of error will ordinarily be managed by the offending Ethernet adapter itself, in which case the Jabber LED will return to its normal off (dark) state.

### ◆ Collision LED

One Collision LED for all ports. A collision occurs when two stations within a collision domain attempt to transmit at the same time. Intermittent flashing yellow of the Collision LED is normal; the contending adapters resolve each collision by means of a wait-then-retransmit algorithm. Frequency of collisions is an indicator of heavy traffic on the network.



## ◆ Link/Rx LEDs

One Link/Rx LED for each numbered port. Steady green (**Link** state) indicates that the port has good linkage to its partner device. Flashing green (**Receive** state) indicates that the port is receiving data from its partner device.

If the port is connected but the Link/Rx LED is dark, check whether (1) the Ethernet Hub and the partner device both have power, (2) the port's cable is firmly seated in its connectors in the Ethernet Hub and in the partner device, (3) the connecting cable is good and is of the correct type, and (4) the partner device, including any network adapter, is functioning.

---

## Specifications

---

Data transfer rate:	10 Mbps
Protocol:	CSMA/CD
Topologies:	Star, Bus
EMI Certification:	FCC Class A, VCCI 1, CE A
AC power:	100 - 240 V , 50 - 60 Hz
Power consumption:	DE-812TP+: 18 W
	DE-816TP: 18 W
	DE-824TP: 20 W

---

Dimensions:	W x H x L, mm (including mounting brackets):	
	DE-812TP+:	483x44 125
	DE-81 6TP:	483x44 125
	DE-824TP	483x44 211
Weight:	DE-81 2TP+:	2.0 kg
	DE-816TP:	2.0 kg
	DE-824TP:	3.03 kg
Operating temperature:	0" - 55" c	
Humidity:	10 - 90 % non-condensing	
Power cord:	Type 1 (US) or Type 2 (Europe) per purchase order	
	Type 1	Type 2
Plug Rating	125V, 7A	250V, 10A
Cord Rating	125V, 7A	250V, 10A
Length	1830mm (6ft)	1830mm (6ft)
Safety Standard	UL, CSA	VDE

## *D-Link Office*

- USA** 5 Musick, Irvine, CA92618, U.S.A.  
Tel. 1-714-455-1688 Fax.1-714-455-2521
- Canada** 2180 Durwin Driver, Unib#6, Mississauga, Ontario,  
L5L 5M8, Canada  
Tel. 1-905-828-0260 Fax. 1-905-828-5669
- UK** D-Link House, 6 Garland Road, Stanmore,  
London HA7 1DP, U.K.  
Tel. 44-181-235-555s Fax. 44-181-235-5500
- Germany** Auf Der Krautweide 32,65812 Bad Soden, Germany  
Tel. 49-6196-643011 Fax. 49-6196-28049
- France** Le Florilege 2, Allee de la Fresnerie, 78330  
Fontenay Le Fleury, France  
Tel. 33-1-30.23.86.88 Fax. 33-1-30-23.86.89
- Sweden** World Trade Center, P.O.Box 70396,107 24 Stockholm,  
Sweden  
Tel. 46-08-70062 11 Fax. 46-08-219640
- Australia** Unit 16,390 Eastern Valley Way, Roseville, NSW 2069,  
Australia  
Tel. 61-2-9417-7100 Fax. 61-2-9417-1077
- Denmark** Naverland 2 DK-2600 Glostrup Copenhagen, Denmark  
Tel. 45-43-96-90-40 Fax. 45-43-42-43-47
- Singapore** 77 Science Park Drive, #03-03 CINECH HI,  
Singapore Science Park, Singapore 118256  
Tel. 65-7746233 Fax. 65-7746322
- Japan** IOF, 8-8-15 Nishgotsndn, Shinagwa-ku, Tokyo 141,  
Japan  
Tel. 81-3-5434-9678 Fax. 81-3-5434-9868
- China** 15<sup>th</sup> Floor, Science & Technology Tower1  
No. 11 Baishiqino Road, Haidinn District,  
Beijing 100081, China  
Tel. 86-10-68467106 Fax. 86-10-68467110
- India** Plot No.5, Kurla-Bandra Complex Rd,  
OFF CST Rd., Santacruz (E) Bombay-400 098 India  
Tel. 91-22-61 1-2788 Fax. 91-22-617-2476
- Taiwan** 2F, No.232, Pao-Chiao Road, Hsin-Tiea, Taipei,  
Taiwan, R.O.C.  
Tel. 886-2-9161600 For. 886-2-9146299